

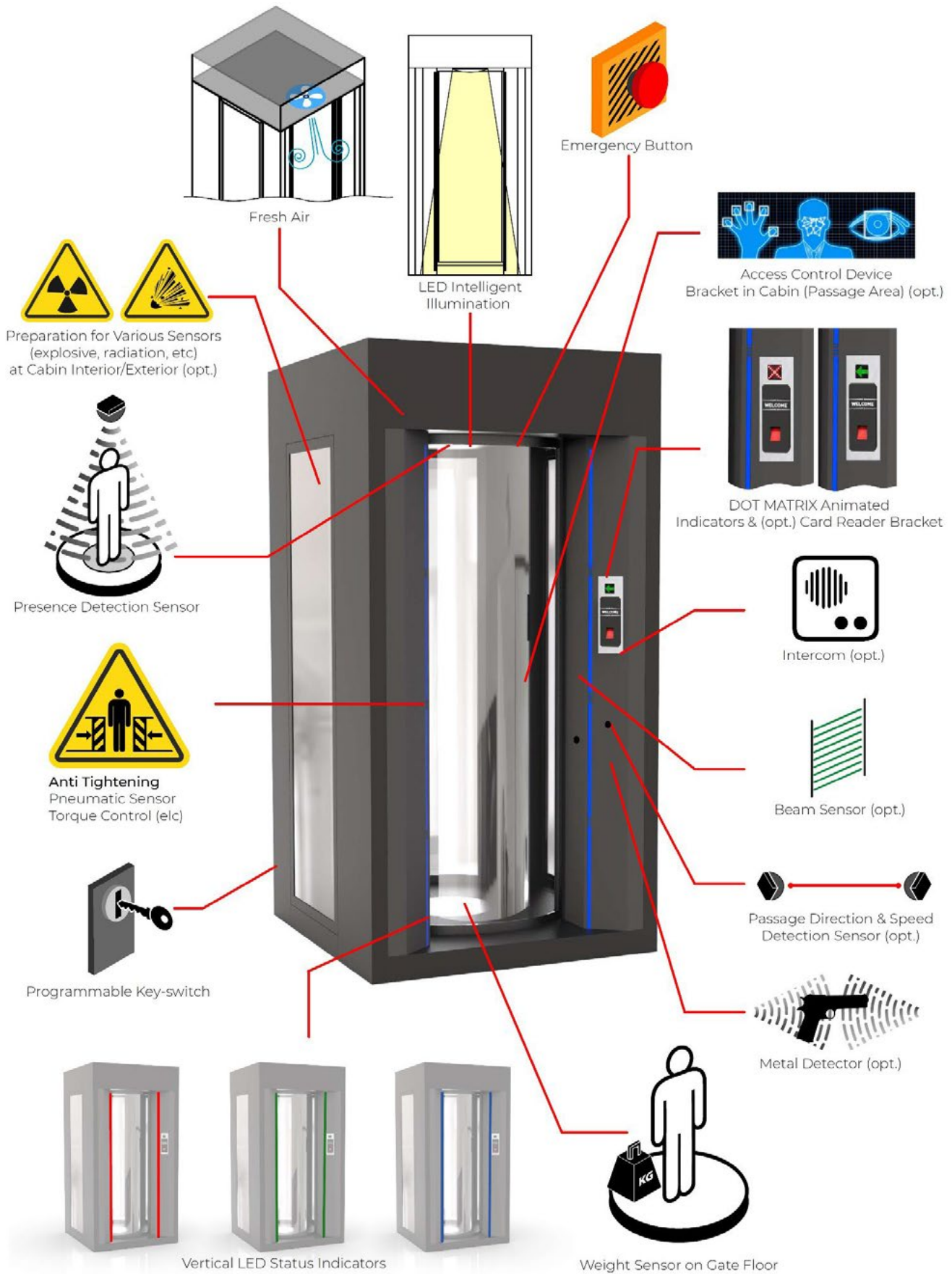

- ❖ Access control solution with wide options developed for high security requirements,
- ❖ DOT MATRIX animated semaphore indicators (entry and exit),
- ❖ Vertical LED status indicators,
- ❖ Emergency button,
- ❖ Anti-tightening feature,
- ❖ Presence detection sensor,
- ❖ Presence detection by multi-proportional load cell (weight sensor) with <1% sensitivity on gate floor,
- ❖ Programmable key-switch button for cleaning-maintenance and manual control,
- ❖ LED interior illumination system,
- ❖ Continuous fresh air ventilation in cabin (passage area),
- ❖ Tailgate control,
- ❖ Optional metal detector,
- ❖ Optional BR class bullet-proof glass,
- ❖ Access control device installation preparation.





### GENERAL SPECIFICATIONS

<b>Dimensions</b>	<p><i>Outer Dimensions</i> : 1200 x 1500 x 2500 mm (1200 x 1500 x 2500 mm with metal dedector)</p> <p><i>Interior (passage area) Dimensions:</i> 1040 x 1140 x 2050 mm</p> <p><i>Clearance, entry-exit width</i> : 700 mm</p> <p><i>Useful Height</i> : 2050 mm</p> <p><i>Net / Gross Weight</i> : (approx.) 450 / 800 kg</p> <p><i>Packed dimensions</i> : (approx.) 1400 x 1400 x 2760 mm</p>
<b>Power</b>	<p>110/220 V AC – 60/50 Hz (% ± 10).</p> <p>Stand-by: ~54 W, passage: ~310 W.</p>
<b>Body Specifications</b>	Electrostatic powder coated steel, optional decorative stainless steel
<b>Side Walls</b>	4+4mm laminated glass (opt. BR class laminated glass)
<b>Rotating Doors</b>	4+4mm laminated glass, curved (opt. BR class laminated glass)
<b>Illumination</b>	LED interior illumination on ceiling providing energy saving and lighting comfort.
<b>Operation Temperature / Humidity / IP Rating</b>	(-20°C) – (+68°C) (opt:- 50°C with heater positive) , RH 95% (±2%) non-condensing), IP 44, for indoor use
<b>MCBF</b>	1.000.000 passages.
<b>Passage Speed</b>	7-8 persons/minute

### SYSTEM SPECIFICATIONS

<b>Indicators and Signalization</b>	<p>DOT MATRIX animated semaphore indicators on vertical beams on each side which determines passage status of the gate.</p> <p>Illuminates red cross for restricted access, sliding green arrow for free to access. It is possible to transmit alfa-numeric messages (CLOSED, company logo, etc.).</p> <p>Sliding green arrow on both sides at stand by position indicate that the gate is ready for access in both directions.</p> <p>Upon authorization, indicator on entry side keeps sliding green arrow while indicator on opposite side turns into red cross.</p> <p>Gate interiors are equipped with LED status indicators on the ceiling; white at stand-by, green during passage, red during door closing and at alarm situation.</p> <p>Also contains vertical LED indicators integrated on main load-bearing columns illuminating; blue at stand-by, green upon passage authorization and red at door closings after a passage end or time-out and at alarm situations.</p>
<b>Electronic Control System</b>	Microprocessor controlled, programmable and compatible with any kind of access control system, remote access to all functions and parameters via TCP/IP.
<b>Control System</b>	<p>Customer specific passage algorithm.</p> <p>Position controlled (with encoder) motor driven, electronic torque controlled system.</p> <p>Functions such as all sensors, motors, indications, switch scenarios and alarms are controlled by an electronic control unit with a programmable microprocessor.</p> <p>Thanks to the microcontroller, no re-adjustment necessary even after any power failure.</p> <p>The electronic control unit is placed in the main load-bearing columns of the gate.</p> <p>Can be controlled by dry contact (ground control).</p> <p>Access can be restricted externally by enable/disable feature despite access authorization.</p>

---

The gate is built with a microprocessor controlled industrial design, resistant to vibration and that can be adapted to meet the demands of any user.

All inputs and outputs are opto-coupler protected.

Passage directions can easily be adjusted with dip-switch as; free passage for control purpose, active, passive or combination of these alternatives.

2 independent mechanical systems which drive the doors are controlled by a single electronic control unit.

Rotation and limiting of the doors are controlled by P.I.D. system with encoder control. Rotation speed of the doors are continuously checked with the data gathered from encoder and motor driver card automatically keeps the speed at the same level and does not allow slow or fast rotation.

Gate includes an electronic control card and all movements and outputs are regulated by this card. In case of need, an RS485 protocol output for PC is optionally available.

---

**Integration**

Compatible with all card and biometric reader access control systems (barcode and card readers, fingerprint/iris scanner devices etc.) that provide dry contact or grounding outputs.

Can be controlled with LAN (network) or optionally RS232, RS485.

Card reader bracket for various size readers, is standard on main load-bearing columns on both sides.

Optionally column and bracket application is available for access control devices in the cabin (passage area).

---

**Mechanical Specifications**

Auto pivoting elements of the gate mechanics are produced from steel and all elements of the mechanics are made of galvanized steel, aluminum or stainless steel.

All gear and mechanic sections are designed and produced in order not to need lubrication and maintenance for long time and system operates quietly.

Industrial design against vandalism.

Both doors can be controlled independently for automatic fail secure, fail safe or manually in case of power-off situation.

---

**Operation System**

Gate normally in closed position, provides access to the desired direction upon authorization from the access control device (3rd party product).

Gate is equipped with presence detection sensor for detecting the person in the passage area.

In case passage fails to be completed for any reason, the person is always returned to his entry direction.

In case an unauthorized person attempts to enter into the gate when another person exits completing his access, system locks and returns the unauthorized person to his entry direction.

System contains special design and CE certified solenoids which do not heat up more than max. 10°C of -%100 ED environment temperature.

Possible to be equipped with a communication feature from the gate interiors by implementation of intercom device (option).

All functions can be arranged for specific algorithms according to customer requirements.

---

<b>Alarms</b>	System generates audio and/or visual alarm or optionally voice message in case of; <ul style="list-style-type: none"> <li>- a passage could not be completed within the allocated time,</li> <li>- a forcing against the door,</li> <li>- presence of one than single person in the passage area,</li> <li>- person has no access authorization,</li> <li>- activation of emergency button,</li> <li>- any irregular situation detected by interior sensors (if any)</li> </ul>
<b>Time-out</b>	Door closes and system gets into stand-by position at the end of selectable designated time (6 / 8 / 18 sec) or at the end of programmable time in case a person does not proceed in.  Gate generates an alarm in case an authorized person do not leave the passage area.
<b>Output Data</b>	System provides a dry contact, 12-24V DC and TCP/IP (optionally RS232/RS485) passage feedback by relays separately for each direction. All parameters (input and output) can be controlled by remote access (opt.).

## FUNCTIONAL SPECIFICATIONS

<b>Operation Type</b>	Bi-directional, in/out, becomes mass evacuation passageway in case of emergency.
<b>Passages</b>	<p>Gate operation principle: Rotating doors are at closed position for both directions at stand-by (optionally open for one direction). Person requests passage authorization from access control device (3rd party product). Upon authorization, entry door opens to grant access for the person. Metal volume on the person is measured by metal detector (opt.) if any, and in case of detection of metal on the person, his passage to the secured side will be prevented and gate will generate alarm.</p> <p>Upon detection of the person in the gate by the presence detection sensors on the ceiling, entry door closes (in case the person does not proceed in, door closes at time-out). At closed status of both doors, the presence detection sensors check again the presence of the person inside. In case of detection of presence, exit doors open and grants passage (otherwise door never opens). Upon exit of the person, the exit door closes and system turns into stand-by for next passage (figure-1).</p> <p>Gate can be equipped with a 2nd level access control system (3rd party product) inside the passage area which allows the person to request further authorization to gain access. Upon authorization, exit door opens and grant the person passage, otherwise entry door opens and person returns to the direction he came from. In both cases, the doors return to their stand-by position after the passage area is cleared by the person.</p> <p>In case of detection of unwanted object by metal detector (optional), system will not allow access to the secured side. System can be programmed for such a case that, the person to be allowed to exit to his entry direction or to be trapped inside for intervention of an operator.</p>
<b>Speed / Flow Rate</b>	<p>Door opening and closing speed: 2 sec. Single person passage time(*) :10 - 12 sec., 5 - 6 person/min. (single way traffic), figure-1, Single person passage time (*): 7 - 8 sec., 7 - 8 person/min. (double way traffic), figure-2. (*) Does not contain the time consumed by access control system.</p>
<b>Safety</b>	<p>Pneumatic soft pressure sensors on moving doors,</p> <p>In addition to the pneumatic sensors, moving doors contain electronic torque control,</p> <p>Continuous static and fresh air circulation inside the gate body,</p>

Emergency push button in the gate passage area,

Shutterproof laminated glass.

**Emergency Mode and Power-off Situation**

In case of fire or other emergency signal; both doors open automatically to provide rapid evacuation (fail safe), figure-7.

In case of an emergency situation during passage; person inside can open the door (at his entry direction) to exit by the emergency push button located in the passage area. Emergency push button may be reset manually by the person or the operator.

In case of power failure; both doors open (fail safe) with power-free automatic opening feature driven by the internal battery.

Manual override function for both doors is optionally available for power-off situations.

Locked status of doors (fail secure) is optionally available.

Gate can maintain operation in case of power-off situation with battery back-up (optional).

**Cleaning-Maintenance, Manual Control Button**

Gate is equipped with a programmable key switch button on one side of the gate adjacent to the door.

This button is programmable for the function desired by the user and set as default for opening one door for cleaning-maintenance or other purpose.

Optionally, by activating the button;

- the door on the same side opens and both doors become free to rotate manually for easy cleaning, or
- can be programmed for various requests (i.e. manually evacuation of the person inside, unlocking of 1st or 2nd door, etc.)

**CERTIFICATION**

Compliance CE, RoHS, TSEK, EAC

**OPTIONAL ACCESSORIES AND APPLICATIONS**

- Bracket, guide and support for all kinds of access control devices in the cabin (passage area) for 2nd level control,
- Intercom internal unit,
- Manual remote control unit (with 10mt cable),
- Audio messages for passage guidance,
- Presence detection sensor,
- Battery back-up,
- Sensor tiers for detection of entering and exiting persons,
- Built-in metal detector,
- BR class glass side walls and doors,
- Wall mounting apparatus,
- Adaptable to RC-VK requirements,
- LCD monitor / projection monitor on reflected on glass door,

- Disassembled transportation option

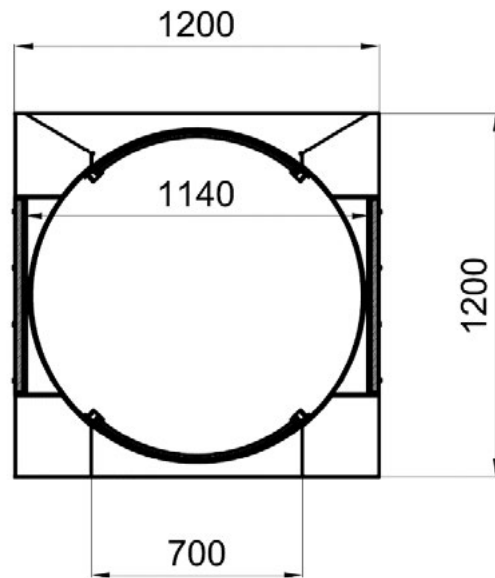
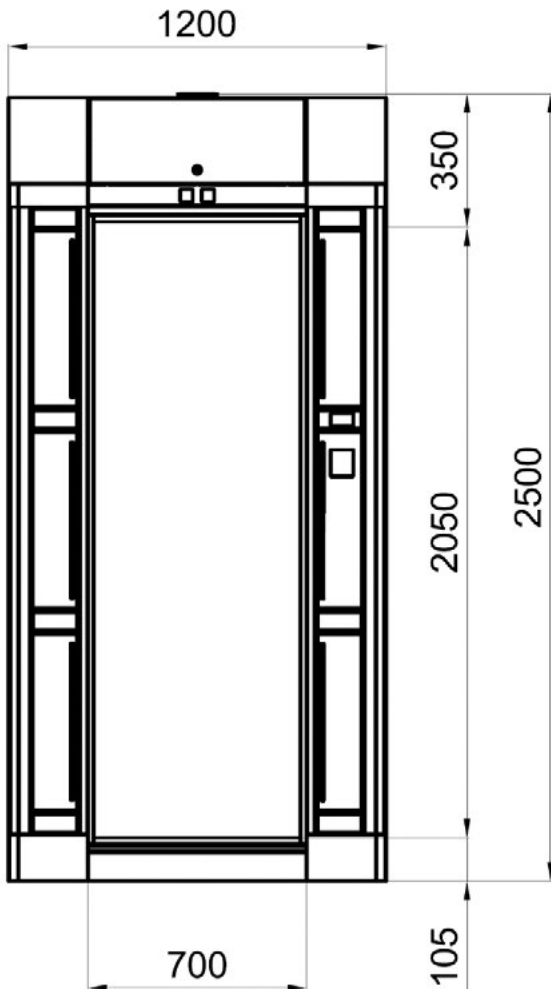

**Authorized Access - Single Way Traffic** (Figure-1)

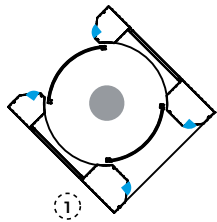

**At stand-by;**

Vertical LED indicators;  
Entry Direction: **Blue**  
Exit Direction : **Blue**  
DOT MATRIX indicators;  
Entry Direction: **➔**  
Exit Direction : **➔**  
Interior Indicators; **□**

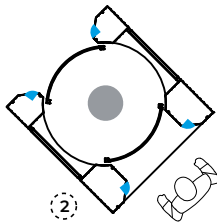

**Person approaches to the gate at stand-by position**

Vertical LED indicators;  
Entry Direction: **Blue**  
Exit Direction : **Blue**  
DOT MATRIX indicators;  
Entry Direction: **➔**  
Exit Direction : **➔**  
Interior Indicators; **□**

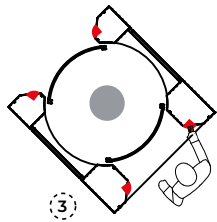

**Person gets access authorization (by card reader etc.)**

Vertical LED indicators;  
Entry Direction: **Red**  
Exit Direction : **Red**  
DOT MATRIX indicators;  
Entry Direction: **✗**  
Exit Direction : **✗**  
Interior Indicators; **●**

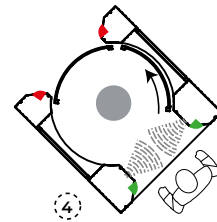

**Entry door opens to let the authorized person to enter in the gate**

Vertical LED indicators;  
Entry Direction: **Green**  
Exit Direction : **Red**  
DOT MATRIX indicators;  
Entry Direction: **✗**  
Exit Direction : **✗**  
Interior Indicators: **●**

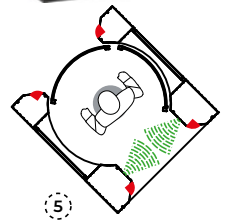

**Person proceeds in. Upon approval from metal detector, system proceeds to next step.**

Vertical LED indicators;  
Entry Direction: **Red**  
Exit Direction : **Red**  
DOT MATRIX indicators;  
Entry Direction: **✗**  
Exit Direction : **✗**  
Interior Indicators; **●**

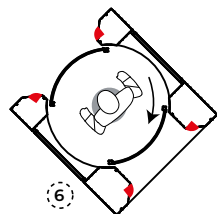

**Entry door closes (\*)**

Vertical LED indicators;  
Entry Direction: **Red**  
Exit Direction : **Red**  
DOT MATRIX indicators;  
Entry Direction: **✗**  
Exit Direction : **✗**  
Interior Indicators; **●**

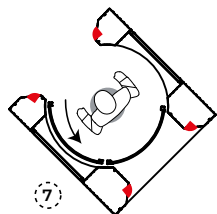

**Exit door opens after 2nd level access control approval (\*\*)**

Vertical LED indicators;  
Entry Direction: **Red**  
Exit Direction : **Red**  
DOT MATRIX indicators;  
Entry Direction: **✗**  
Exit Direction : **✗**  
Interior Indicators; **●**

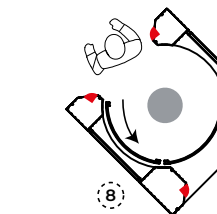

**Person completes access by leaving the gate**

Vertical LED indicators;  
Entry Direction: **Red**  
Exit Direction : **Red**  
DOT MATRIX indicators;  
Entry Direction: **✗**  
Exit Direction : **✗**  
Interior Indicators; **●**

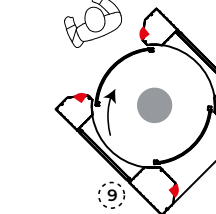

**Exit door closes**

Vertical LED indicators;  
Entry Direction: **Red**  
Exit Direction : **Red**  
DOT MATRIX indicators;  
Entry Direction: **✗**  
Exit Direction : **✗**  
Interior Indicators; **●**

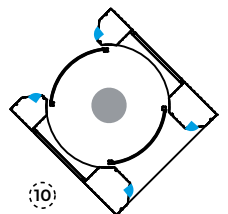

**Gate returns to stand-by status**

Vertical LED indicators;  
Entry Direction: **Blue**  
Exit Direction : **Blue**  
DOT MATRIX indicators;  
Entry Direction: **➔**  
Exit Direction : **➔**  
Interior Indicators; **□**

\* Optional 2nd level access control (by 3rd parties) can be implemented.

\*\* Optional 2nd level access control implemented.



## Authorized Access - Double Way Traffic (Figure-2)

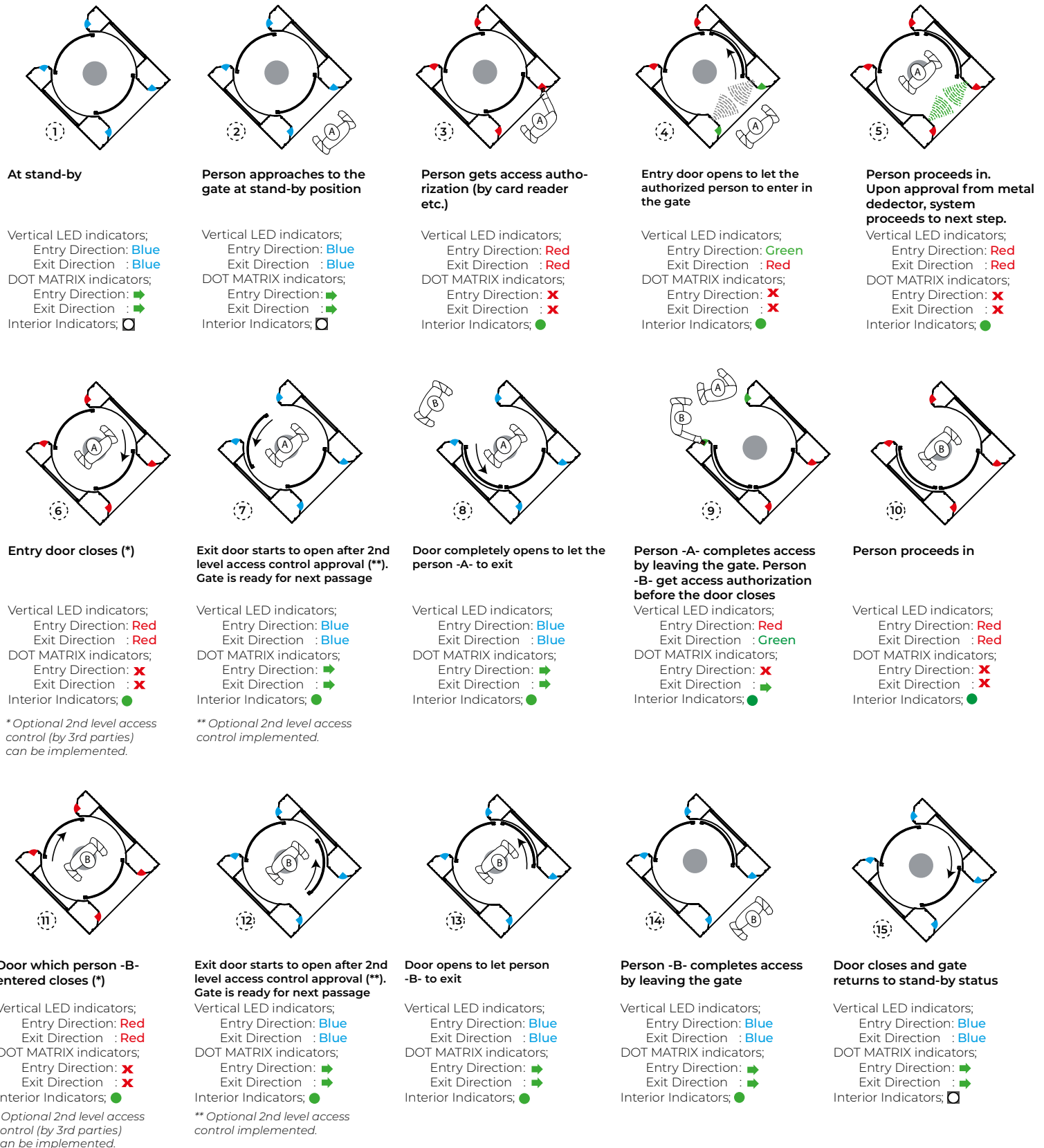

## Unauthorized Access Attempt (Figure-3) (by metal detector or 2nd level access control)

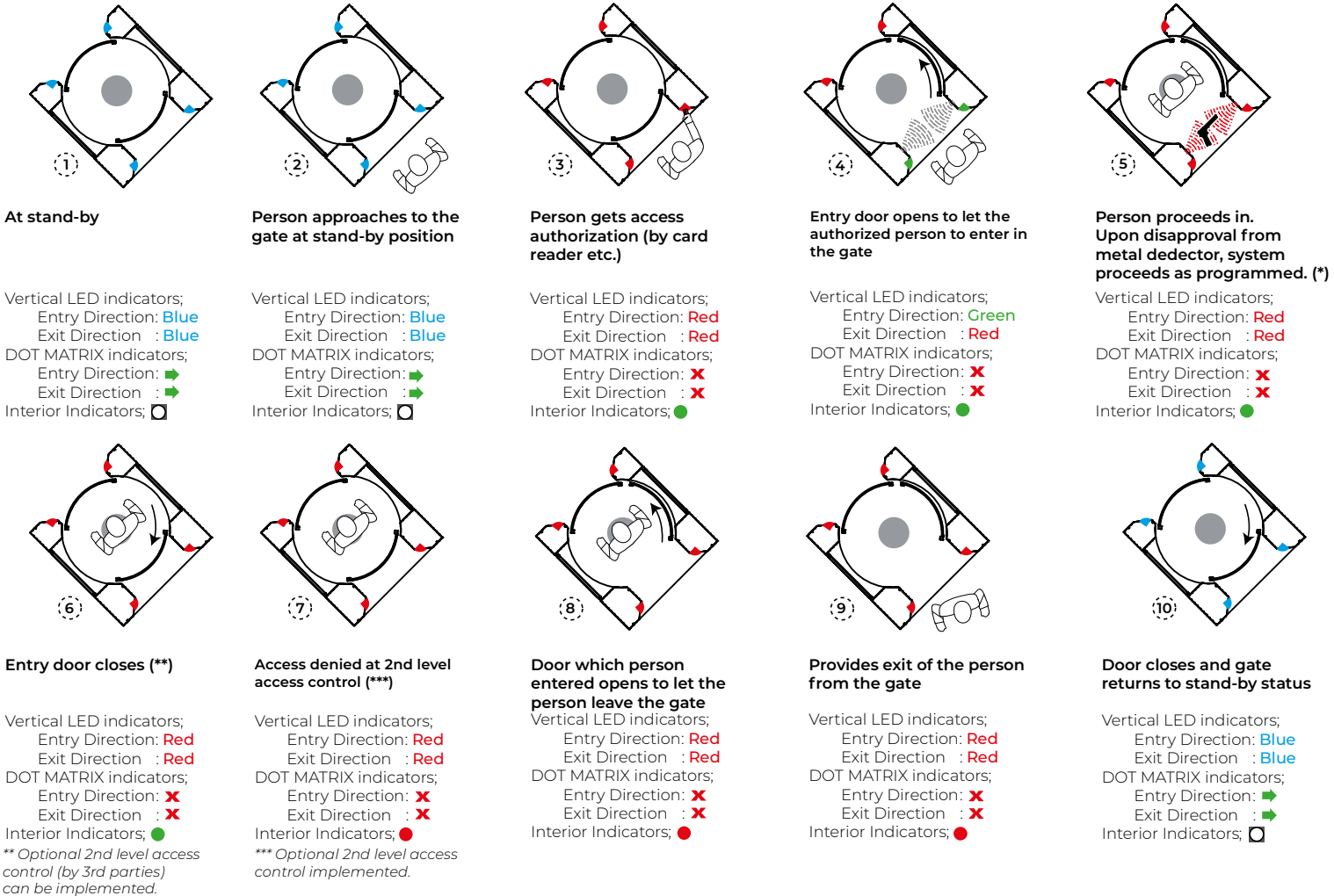

- (\*)** » System generates audio-visual alarm  
 » Alternative 1: Entry door never closes.  
 » Alternative 2: In case entry door is closed;  
     **a-** system traps person inside and waits for operator,  
     **b-** entry door opens (immediately or at the end of time-out)  
         enabling person inside to exit to his entry direction.

## Unauthorized (more than one person) (Figure-4) Access Attempt

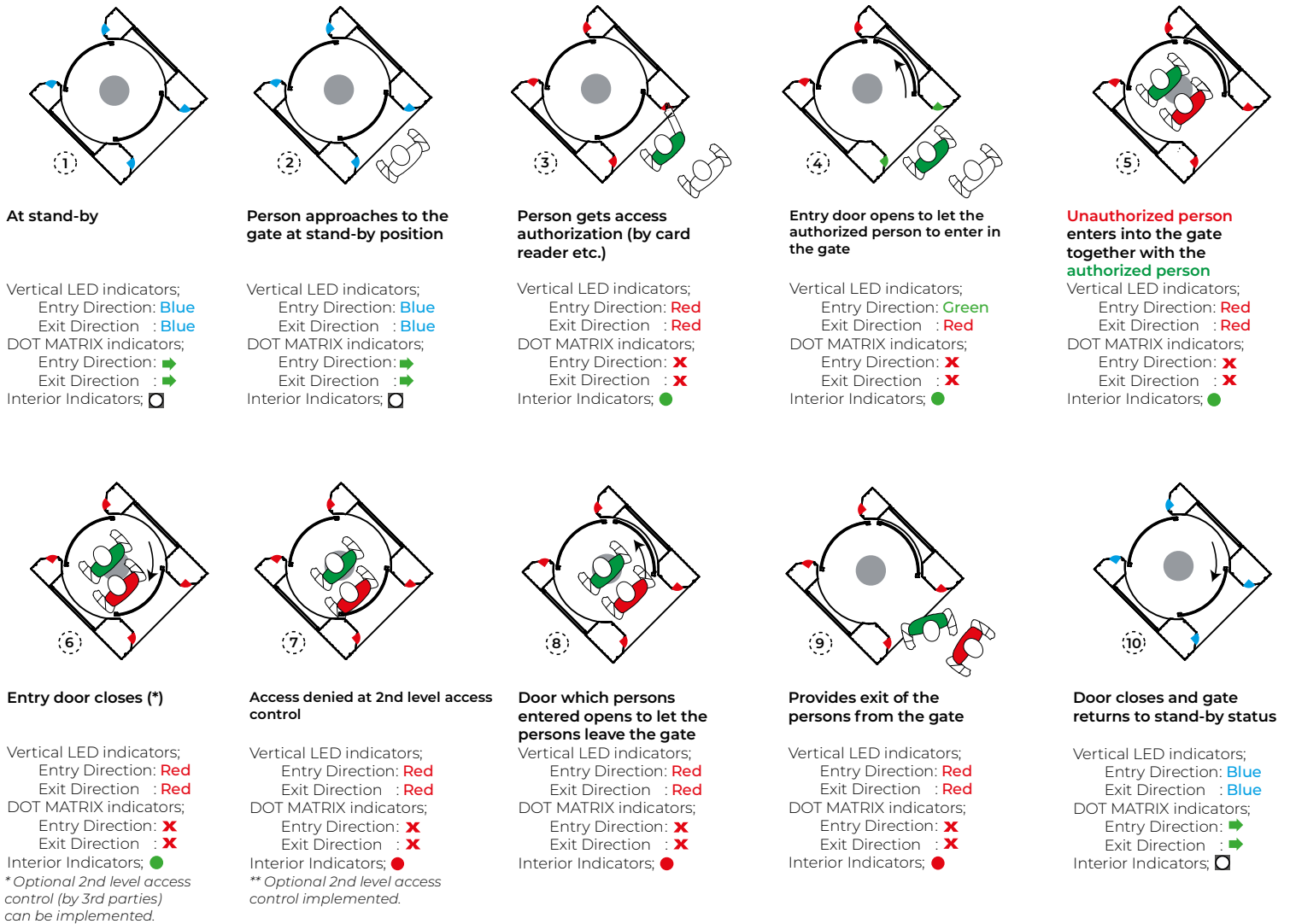

## Violation from Exit Direction (Figure-5)

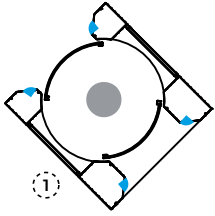

At stand-by

Vertical LED indicators;  
Entry Direction: **Blue**  
Exit Direction : **Blue**  
DOT MATRIX indicators;  
Entry Direction: **➔**  
Exit Direction : **➔**  
Interior Indicators;

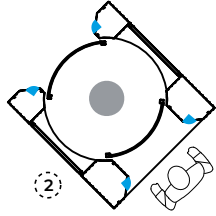

Person approaches to the gate at stand-by position

Vertical LED indicators;  
Entry Direction: **Blue**  
Exit Direction : **Blue**  
DOT MATRIX indicators;  
Entry Direction: **➔**  
Exit Direction : **➔**  
Interior Indicators;

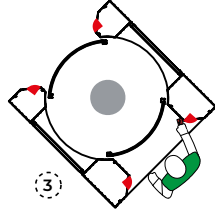

Person gets access authorization (by card reader etc.)

Vertical LED indicators;  
Entry Direction: **Red**  
Exit Direction : **Red**  
DOT MATRIX indicators;  
Entry Direction: **✗**  
Exit Direction : **✗**  
Interior Indicators;

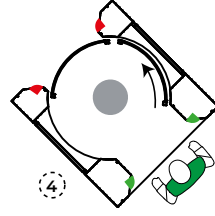

Entry door opens to let the authorized person to enter in the gate

Vertical LED indicators;  
Entry Direction: **Green**  
Exit Direction : **Red**  
DOT MATRIX indicators;  
Entry Direction: **✗**  
Exit Direction : **✗**  
Interior Indicators;

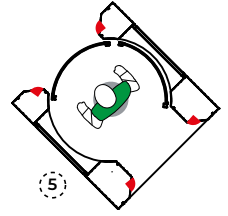

Person proceeds in

Vertical LED indicators;  
Entry Direction: **Red**  
Exit Direction : **Red**  
DOT MATRIX indicators;  
Entry Direction: **✗**  
Exit Direction : **✗**  
Interior Indicators;

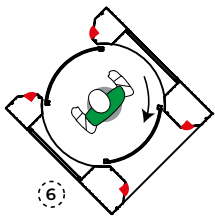

Entry door closes (\*)

Vertical LED indicators;  
Entry Direction: **Red**  
Exit Direction : **Red**  
DOT MATRIX indicators;  
Entry Direction: **✗**  
Exit Direction : **✗**  
Interior Indicators;

\* Optional 2nd level access control (by 3rd parties) can be implemented.

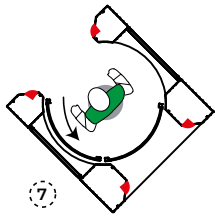

Exit door opens after 2nd level access control approval (\*\*)

Vertical LED indicators;  
Entry Direction: **Red**  
Exit Direction : **Red**  
DOT MATRIX indicators;  
Entry Direction: **✗**  
Exit Direction : **✗**  
Interior Indicators;

\*\* Optional 2nd level access control implemented.

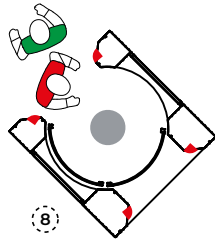

Authorized person completes access by leaving the gate whilst unauthorized person enters before the door is closed

Vertical LED indicators;  
Entry Direction: **Red**  
Exit Direction : **Red**  
DOT MATRIX indicators;  
Entry Direction: **✗**  
Exit Direction : **✗**  
Interior Indicators;

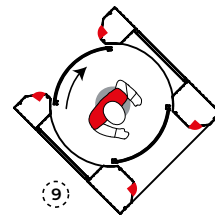

Exit door closes, system detects unauthorized entry

Vertical LED indicators;  
Entry Direction: **Red**  
Exit Direction : **Red**  
DOT MATRIX indicators;  
Entry Direction: **✗**  
Exit Direction : **✗**  
Interior Indicators;

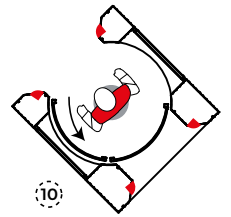

Door which unauthorized person entered opens

Vertical LED indicators;  
Entry Direction: **Red**  
Exit Direction : **Red**  
DOT MATRIX indicators;  
Entry Direction: **✗**  
Exit Direction : **✗**  
Interior Indicators;

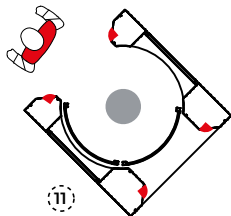

Provides exit of the person from the gate

Vertical LED indicators;  
Entry Direction: **Red**  
Exit Direction : **Red**  
DOT MATRIX indicators;  
Entry Direction: **✗**  
Exit Direction : **✗**  
Interior Indicators;

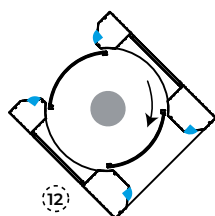

Door closes and gate returns to stand-by status

Vertical LED indicators;  
Entry Direction: **Blue**  
Exit Direction : **Blue**  
DOT MATRIX indicators;  
Entry Direction: **➔**  
Exit Direction : **➔**  
Interior Indicators;

## Interior Emergency (Panic) (Figure-6) Button Operation

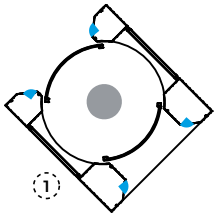

**At stand-by**

Vertical LED indicators;  
Entry Direction: **Blue**  
Exit Direction : **Blue**  
DOT MATRIX indicators;  
Entry Direction: **➔**  
Exit Direction : **➔**  
Interior Indicators;

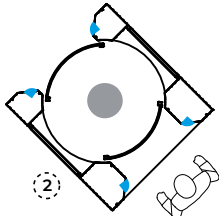

**Person approaches to the gate at stand-by position**

Vertical LED indicators;  
Entry Direction: **Blue**  
Exit Direction : **Blue**  
DOT MATRIX indicators;  
Entry Direction: **➔**  
Exit Direction : **➔**  
Interior Indicators;

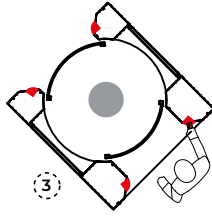

**Person gets access authorization (by card reader etc.)**

Vertical LED indicators;  
Entry Direction: **Red**  
Exit Direction : **Red**  
DOT MATRIX indicators;  
Entry Direction: **✗**  
Exit Direction : **✗**  
Interior Indicators;

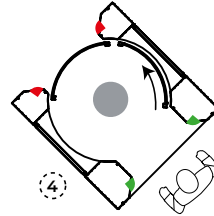

**Entry door opens to let the authorized person to enter in the gate**

Vertical LED indicators;  
Entry Direction: **Green**  
Exit Direction : **Red**  
DOT MATRIX indicators;  
Entry Direction: **✗**  
Exit Direction : **✗**  
Interior Indicators;

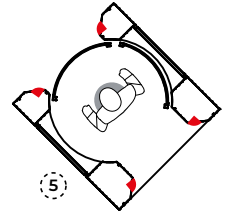

**Person proceeds in**

Vertical LED indicators;  
Entry Direction: **Red**  
Exit Direction : **Red**  
DOT MATRIX indicators;  
Entry Direction: **✗**  
Exit Direction : **✗**  
Interior Indicators;

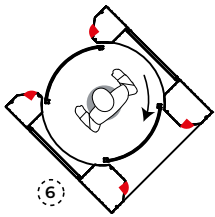

**Entry door closes (\*)**

Vertical LED indicators;  
Entry Direction: **Red**  
Exit Direction : **Red**  
DOT MATRIX indicators;  
Entry Direction: **✗**  
Exit Direction : **✗**  
Interior Indicators;

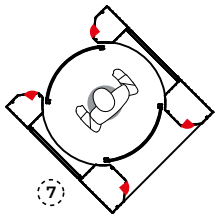

**In case of any emergency situation, emergency button inside the gate can be used**

Vertical LED indicators;  
Entry Direction: **Red**  
Exit Direction : **Red**  
DOT MATRIX indicators;  
Entry Direction: **✗**  
Exit Direction : **✗**  
Interior Indicators;

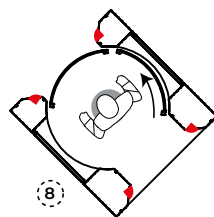

**Door which the person entered into the gate opens**

Vertical LED indicators;  
Entry Direction: **Red**  
Exit Direction : **Red**  
DOT MATRIX indicators;  
Entry Direction: **✗**  
Exit Direction : **✗**  
Interior Indicators;

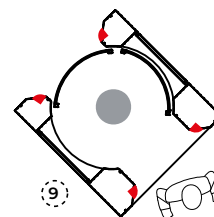

**Provides exit of the person from the gate**

Vertical LED indicators;  
Entry Direction: **Red**  
Exit Direction : **Red**  
DOT MATRIX indicators;  
Entry Direction: **✗**  
Exit Direction : **✗**  
Interior Indicators;

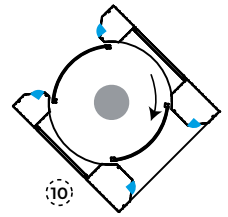

**Gate returns to stand-by status upon resetting the emergency button**



Vertical LED indicators;  
Entry Direction: **Blue**  
Exit Direction : **Blue**  
DOT MATRIX indicators;  
Entry Direction: **➔**  
Exit Direction : **➔**  
Interior Indicators;

\* Optional 2nd level access control (by 3rd parties) can be implemented.

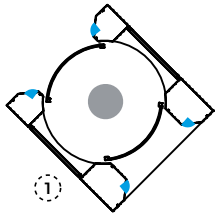
## Mass Evacuation (Figure-7)



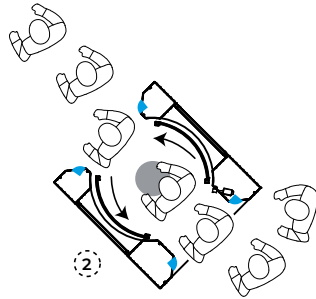

**At stand-by**

Vertical LED indicators;  
Entry Direction: **Blue**  
Exit Direction : **Blue**  
DOT MATRIX indicators;  
Entry Direction:   
Exit Direction :   
Interior Indicators;



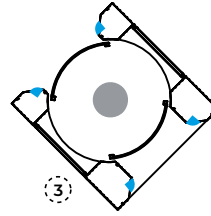

**In case of any alarm situation, both doors open for mass evacuation**

Vertical LED indicators;  
Entry Direction: **Green**  
Exit Direction : **Green**  
DOT MATRIX indicators;  
Entry Direction:   
Exit Direction :   
Interior Indicators;



**Gate returns stand-by upon termination of alarm situation**

Vertical LED indicators;  
Entry Direction: **Blue**  
Exit Direction : **Blue**  
DOT MATRIX indicators;  
Entry Direction:   
Exit Direction :   
Interior Indicators;